

To order, go to: <https://www.barrierwarehouse.com/Tensacone-Topper-7-13-ft-Belt-p/tc114.htm>



TC114 Tensacone Topper

Part of the world's first and largest range of retracting belt barriers.

Designed to fit over most standard traffic cones (requires a cone weight), the Tensacone® Topper turns a line of traffic cones into a barrier. Ideal for use anywhere where traffic cones are used to restrict access Tensacone® is light weight and fast to set up. Each Tensacone® has 13' of heavy duty belt, simply connect any number of cones together to make a barrier of any size. Ideal for use in maintenance areas, roadside construction, engineering applications or anywhere where a temporary barrier is required.

Specifications:

Construction: heavy duty plastic

Weight: 0.8 lbs

Belt Length: 13'

Colors: orange, blue, green and yellow

Belt: yellow/black, red/white, green/white
blue/white diagonal stripe

Features and Benefits

- > easy to connect retracting belt provides a quick and effective method to restrict traffic access
- > more effective at restricting access than cones alone
- > more reliable than string or traffic tape
- > lighter and easier to set up than rigid barriers
- > fewer cones required saving storage space and money
- > four way connectivity feature enables any shape cordon to be created – square, triangle, U etc
- > robust construction made to withstand heavy duty use



Product Shown:

Tensacone® Topper orange with red chevron belt. Shown with recommended cone weight



Product Shown:

Standard traffic cones require a cone weight (sold separately) alternatively heavy-weight cones available from Lawrence.

For more information:
Call: 800-500-9980 • Fax: 312-300-4808
Order Online: www.BarrierWAREHOUSE.com

Email: sales@barrierwarehouse.com
Barrier WAREHOUSE, LLC

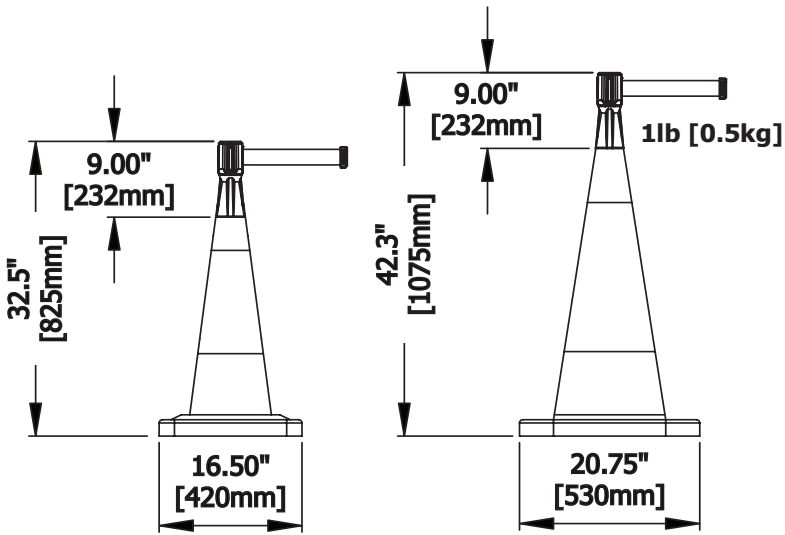

height	232mm	tube O.D.	N/A
base dia.	N/A	weight	0.5kg

Note: The topper & cone are sold separately.
The overall height is the sum of both the topper & cone.



For more information:
Call: 800-500-9980 • Fax: 312-300-4808
Order Online: www.BarrierWAREHOUSE.com

Email: sales@barrierwarehouse.com
Barrier WAREHOUSE, LLC